



**European Communication
Format – B2B**

**Environmental Product
Declaration**

**Polypropylene (PP)
structured (twin) wall sewer
pipe system**

1 DECLARATION OF GENERAL INFORMATION

Introduction

The European Plastics Pipes and Fittings Association (TEPPFA) deems it important to have an insight into the integral environmental impacts that are encountered during the life-span of particular pipe system applications. With this framework in mind, in 2010 TEPPFA has set up an LCA/EPD project with the Flemish Institute for Technological Research (VITO) which resulted in an EPD. The present EPD is the update of the EPD issued in 2011 – foreground data remained the same, with only the datasets being updated to the latest available version (Ecoinvent 3.3 and Industry 2.0 replaced Ecoinvent 2 datasets). It outlines the various environmental aspects, which accompany the polypropylene (PP) structured (twin) wall sewer pipe system, from the primary extraction of raw materials up to and including the end of life (EoL) treatment after its reference service life time.

Name and address of manufacturers

TEPPFA, Avenue de Cortenbergh, 71, B-1000 Brussels, Belgium, Tel: +32-2-736 24 06, Fax: +32-2-736 58 82, E-Mail: info@teppfa.eu, <http://www.teppfa.eu>

PP pipe system's use and functional unit

The EPD refers to a typical European PP structured (twin) wall sewer pipe system, from the cradle to the grave, including raw material extraction, transportation to converters, converting process, transport to trench, construction, use and end of life. Environmental indicators are expressed for the complete life cycle, from the cradle to the grave, so for an average European PP structured (twin) wall sewer pipe system. The functional unit is defined as "The below ground gravity transportation of sewage over a distance of 100 m by a typical public European PP structured (twin) wall pipe system (DN/ID 300 mm) from the entrance of a public sewer system to the entrance of the waste water treatment plant, over its complete service life cycle of 100 years, calculated per year".

Product name & graphic display of product

PP structured (twin) wall sewer pipe system (civil applications)

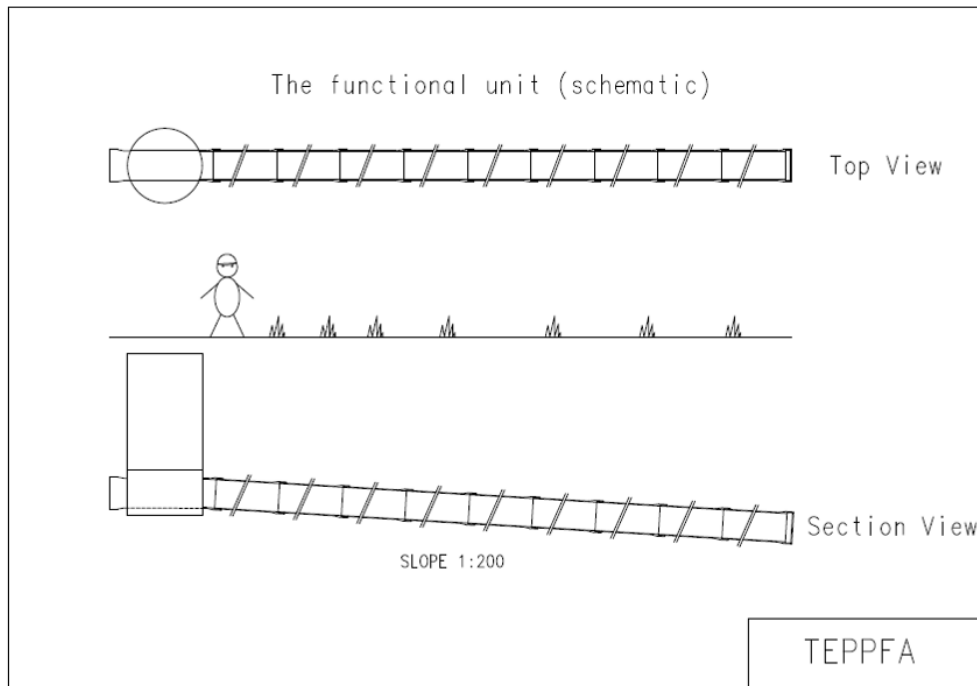

Description of the PP structured (twin) wall sewer pipe system components

The environmental burdens are calculated in relation to the functional unit, which resulted for the typical European PP structured (twin) wall sewer pipe system in the following basic pipe system components: PP pipes, PP fittings, PP manholes and SBR sealing rings.

The system consists of PP structured (twin) wall pipes and fittings, red brown, SN 8, diameter 300 mm, 5 m length, socketed (representative for the typical pipe diameter from the entrance of a public sewer system to the entrance of the waste water treatment plant).

Manhole roughly every 45 meters (630 mm shaft – SMP report, 2005). The manhole covers are not included in the LCA study. Volume of fittings including seals (approximately 5%) calculated based on actual sales data. The pipe system has a reference length of 100 metres; slope 1/200 and filling rate 100%. Service life time of 100 years.

The EPD is declared as the average environmental performance for a typical European PP structured (twin) wall sewer pipe system, over its reference service life cycle of 100 years, calculated per year, in accordance to EN 13476, EN 1295-1 and EN 1610.

EPD programme and programme operator

The present EPD is in line with the ongoing standardization work by CEN TC 350 (EN15804 and EN15942). A programme operator related to the CEN TC 350 has not been established yet.

Date of declaration and validity

June, 2018

The EPD has a 5 year validity period (June, 2023)

Comparability

Please note that EPDs of construction products may not be comparable if they do not comply with the CEN TC 350 (EN15804 and EN15942) standards.

Typical European PP structured (twin) wall sewer pipe system EPD

The present EPD outlines various environmental aspects, which accompany a representative average European PP structured (twin) wall sewer pipe system, from the primary extraction of raw materials up to and including the end of life (EoL) treatment after its reference service life time of 100 years.

Group of manufacturers

The EPD for the PP structured (twin) wall sewer pipe system is representative for an anticipated European typical PP structured (twin) wall sewer pipe system. The TEPPFA member companies represent more than 50% of the European market for extruded plastic pipes. For an overview of all members and national associations within TEPPFA we refer to the last page of this EPD.

Content of the product system

The product system does not contain materials or substances that can adversely affect human health and the environment in all stages of the life cycle.

Retrieve information

Explanatory material may be obtained by contacting TEPPFA (<http://www.teppfa.eu>)

2 DECLARATION OF THE MATERIAL CONTENT

The European Polypropylene (PP) structured (twin) wall sewer pipe system does not contain any substances as such or in concentration exceeding legal limits, which can adversely affect human health and the environment in any stages of its entire life cycle.

3 DECLARATION OF THE ENVIRONMENTAL PARAMETERS DERIVED FROM LCA

3.1 Life cycle flow diagram

The EPD refers to a typical European PP structured (twin) wall sewer pipe system, from the cradle to the grave, including product stage, transport to construction site and construction process stage, use stage and end of life stage.

- **Product stage:** raw material extraction and processing, recycling processes for recycled material input, transport to the manufacturer, manufacturing (including all energy provisions, waste management processes during the product stage up to waste for final disposal):
 - Production of raw materials for PP pipes
 - Transport of PP pipe raw materials to converter
 - Converting process for PP structured (twin) wall pipes (extrusion)
 - Production of raw materials for PP fittings
 - Transport of PP fittings raw materials to converter
 - Converting process for PP fittings (injection moulding)
 - Production raw materials for PP manholes
 - Transport of PP manholes raw materials to converter
 - Converting process for PP manholes (injection moulding)
 - Production raw materials for styrene butadiene rubber (SBR) rings
 - Transport of SBR raw materials to converter
 - Converting process for SBR rings
- **Construction process stage:** including all energy provisions, waste management processes during the construction stage up to waste for final disposal
 - Transport of complete PP structured (twin) wall sewer pipe system to the trench;
 - Installation of complete PP structured (twin) wall sewer pipe system in the trench;
- **Use stage** (maintenance and operational use): including transport and all energy provisions, waste management processes up to waste for final disposal during this use stage
 - Use and maintenance of the complete PP structured (twin) wall sewer pipe system during 100 years of reference service life time;
- **End of life stage:** including all energy provisions during the end of life stage
 - Disassembly of complete PP structured (twin) wall sewer pipe system after 100 years of reference service life time;
 - Transport of complete PP structured (twin) wall sewer pipe system after 100 years of reference service life time;
 - End-of-life waste treatment of complete PP structured (twin) wall sewer pipe system after 100 years of reference service life time.

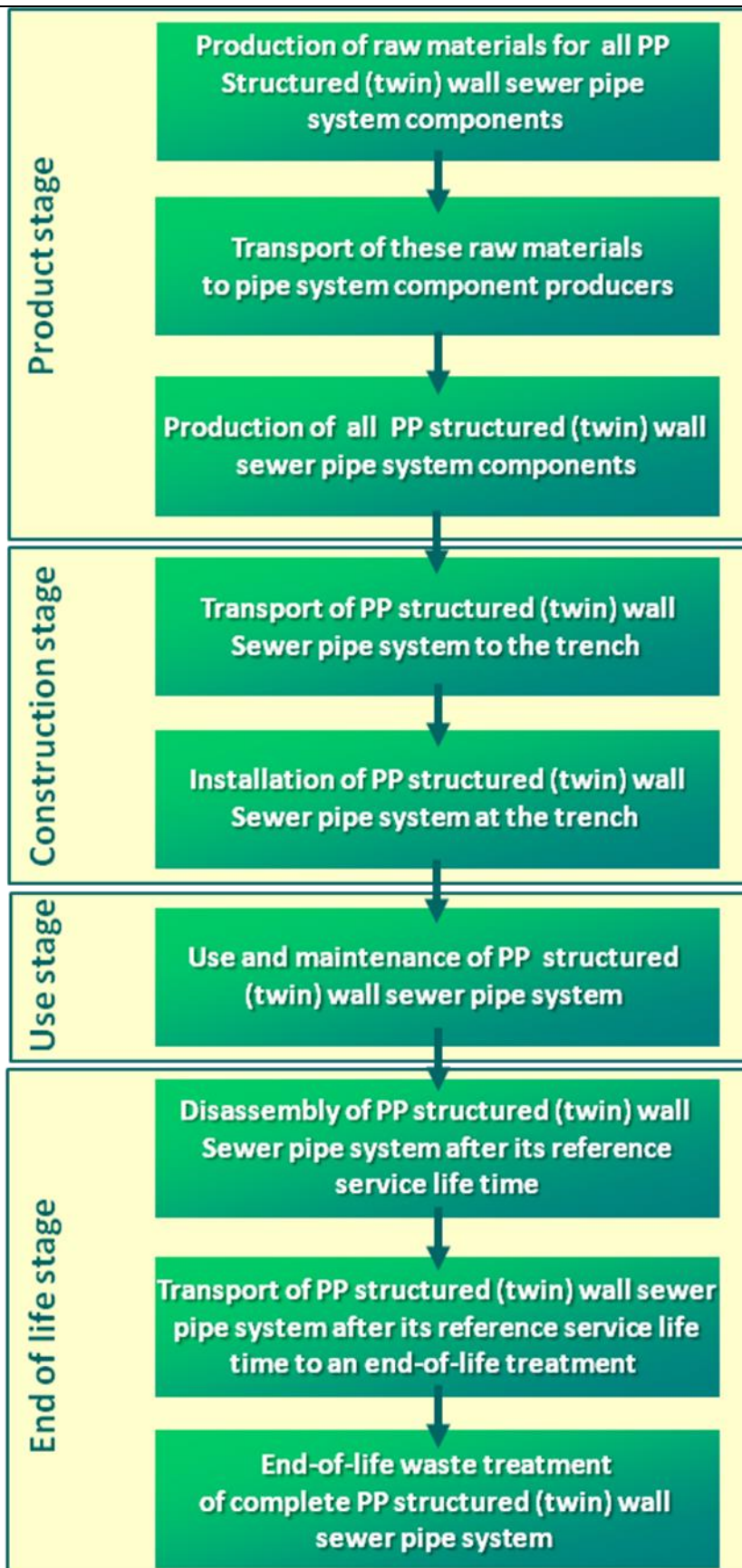

3.2 Parameters describing environmental impacts

The following environmental parameters are expressed with the impact category parameters of the life cycle impact assessment (LCIA).

Impact category	Abiotic depletion (non-fossil)	Abiotic depletion (fossil fuels)	Acidification	Eutrophication	Global warming	Ozone layer depletion	Photochemical oxidation
	kg Sb eq	MJ	kg SO ₂ eq	kg PO ₄ --- eq	kg CO ₂ eq	kg CFC-11 eq	kg C ₂ H ₄ eq
Product stage	5,31E-06	4,80E+02	3,90E-02	8,82E-03	1,26E+01	5,54E-07	2,96E-03
Construction process stage	1,01E-05	1,00E+02	4,35E-02	9,14E-03	6,56E+00	1,26E-06	1,33E-03
Use stage	3,80E-07	1,06E+01	5,22E-03	1,09E-03	7,02E-01	1,24E-07	1,50E-04
End of life stage	9,58E-08	-6,76E-01	-2,21E-04	3,31E-05	3,73E-01	-2,48E-09	-1,93E-05
Total	1,58E-05	5,91E+02	8,75E-02	1,91E-02	2,03E+01	1,93E-06	4,42E-03

3.3 Parameters describing resource input

The following environmental parameters apply data based on the life cycle inventory (LCI).

Environmental parameter	Use of renewable primary energy excluding renewable primary energy resources used as raw materials	Use of renewable primary energy resources used as raw materials	Total use of renewable primary energy resources (primary energy and primary energy resources used as raw materials)	Use of non renewable primary energy excluding non renewable primary energy resources used as raw materials	Use of non renewable primary energy resources used as raw materials	Total use of non renewable primary energy resources (primary energy and primary energy resources used as raw materials)	Use of secondary material	Use of renewable secondary fuels	Use of non renewable secondary fuels	Net use of fresh water
	MJ, net calorific value	MJ, net calorific value	MJ, net calorific value	MJ, net calorific value	MJ, net calorific value	MJ, net calorific value	kg	MJ, net calorific value	MJ, net calorific value	m ³
Product stage	n.a.	n.a.	2,03E+01	n.a.	n.a.	4,88E+02	n.a.	n.a.	n.a.	2,45E-01
Construction process stage	n.a.	n.a.	3,85E+00	n.a.	n.a.	1,07E+02	n.a.	n.a.	n.a.	8,34E-01
Use stage	n.a.	n.a.	1,62E-01	n.a.	n.a.	1,05E+01	n.a.	n.a.	n.a.	1,52E-01
End of life stage	n.a.	n.a.	-4,72E-01	n.a.	n.a.	-2,61E+00	n.a.	n.a.	n.a.	-2,20E-03
Total	n.a.	n.a.	2,38E+01	n.a.	n.a.	6,03E+02	n.a.	n.a.	n.a.	1,23E+00

3.4 Parameters describing different waste categories and further output material flows

The parameters describing waste categories and other material flows are output flows derived from the life cycle inventory (LCI)

Parameters describing different waste categories

Environmental parameter	Hazardous waste	Non-hazardous waste	Nuclear waste
	kg	kg	kg
Product stage	8,48E-02	7,98E-01	3,52E-04
Construction stage	5,49E-05	1,86E+00	8,24E-04
Use stage	6,27E-06	1,79E-02	7,16E-05
End of life stage	-2,90E-06	5,59E+00	-1,27E-05
Total	8,48E-02	8,27E+00	1,23E-03

Parameters describing further output material flows

Parameter	Parameter unit expressed per functional unit
Components for re-use	5,573 kg
Materials for recycling	0,151 kg
Materials for energy recovery	0,160 kg

4 SCENARIOS AND TECHNICAL INFORMATION

4.1 Construction process stage

Transport from the production gate to the construction site (trench)

Parameter	Parameter unit expressed per functional unit
Fuel type consumption of vehicle or vehicle type used for transport e.g. long distance truck, boat etc.	The PP structured (twin) wall sewer pipe system is transported over an average distance of 400 km by means of a truck from the producers of the different pipe system components to the trench. The loading factor for PP structured (twin) wall pipes is limited by volume. Environmental burdens associated with this kind of transport are calculated by means of the Ecoinvent V3.3 datarecord "Transport, freight, lorry 16-32 metric ton, EURO4 {RER} transport, freight, lorry 16-32 metric ton, EURO4 Alloc Rec, U".
Capacity utilisation (including empty returns)	
Bulk density	
Volume capacity utilisation factor (factor: =1 or <1 or ≥ 1 for compressed or nested packaged products)	

Construction (installation at trench)

Parameter	Parameter unit expressed per functional unit
Ancillary materials for installation	0,34 m³ of backfilling sand trucked to trench over an average distance of 10 km. Environmental burdens associated with this kind of energy are calculated by means of the Ecoinvent V3.3 datarecords "Sand {CH} gravel and quarry operation Alloc Rec, U" and "Transport, freight, lorry >32 metric ton, EURO4 {RER} transport, freight, lorry >32 metric ton, EURO4 Alloc Rec, U" Building hall is excluded from the background dataset for sand due to irregularities related to

	the impact on abiotic depletion (non-fossil).																								
Other resource consumption	Not relevant																								
Quantitative description of energy type (regional mix) and consumption during the installation process	44 MJ of mechanical energy is needed for excavating the soil (dig up), for excavating the backfilling soil and sand, for the stamping process (compaction next pipe) and for the vibration plate (compaction top). Environmental burdens associated with this kind of energy are calculated by means of the Ecoinvent V3.3 datarecord "Diesel, burned in building machine {GLO} processing Alloc Rec, U"																								
Waste on the building site, generated by the product's installation	0,09 kg of PP pipe left over during installation: 80% to landfill, 15% to incineration and 5% to mechanical recycling. Transportation of PP pipe left over to waste management treatment facilities is included: 600 km to recycling plant, 150 km to incineration with energy recovery and 50 km to landfill. Environmental burdens are calculated by means of the Ecoinvent V3.3 datarecord "Transport, freight, lorry 3.5-7.5 metric ton, EURO4 {RER} transport, freight, lorry 3.5-7.5 metric ton, EURO4 Alloc Rec, U".																								
Output materials as result of waste management processes at the building site e.g. of collection for recycling, for energy recovery, final disposal	<p>0,24 kg of packaging waste: treated according to European average packaging waste scenarios (EU27, 2006):</p> <table border="1"> <thead> <tr> <th></th> <th>Recycling</th> <th>Energy Recovery</th> <th>Landfill</th> </tr> </thead> <tbody> <tr> <td>Plastic</td> <td>27%</td> <td>26%</td> <td>47%</td> </tr> <tr> <td>Paper and board</td> <td>75%</td> <td>10%</td> <td>15%</td> </tr> <tr> <td>Wood</td> <td>38%</td> <td>23%</td> <td>39%</td> </tr> <tr> <td>Metals</td> <td>66%</td> <td></td> <td>34%</td> </tr> <tr> <td>Total</td> <td>57%</td> <td>12%</td> <td>31%</td> </tr> </tbody> </table> <p>0,43 m³ of soil that has to be transported over an average distance of 5 km to the nearest depot. Environmental burdens are calculated by means of the Ecoinvent V3.3 datarecord "Transport, freight, lorry 3.5-7.5 metric ton, EURO4 {RER} transport, freight, lorry 3.5-7.5 metric ton, EURO4 Alloc Rec, U".</p>		Recycling	Energy Recovery	Landfill	Plastic	27%	26%	47%	Paper and board	75%	10%	15%	Wood	38%	23%	39%	Metals	66%		34%	Total	57%	12%	31%
	Recycling	Energy Recovery	Landfill																						
Plastic	27%	26%	47%																						
Paper and board	75%	10%	15%																						
Wood	38%	23%	39%																						
Metals	66%		34%																						
Total	57%	12%	31%																						
Emissions to ambient air, soil and water	No direct emissions at the trench. Emissions are related to the upstream processes (mining of sand, transportation processes and mechanical energy) and downstream processes (waste management and treatment) and are included in the Ecoinvent datarecords that are used for modelling the environmental impacts.																								

4.2 Use stage: operation and maintenance

Operation:

Operational use is not relevant for the EPD, since it falls outside the system boundaries of the LCA project. Moreover the PP structured (twin) wall sewer pipe system is a gravity pipe system.

Maintenance:

Energy consumption for jetting: 7 MJ per FU

Water consumption for jetting: 0,15 m³ per FU

Maintenance in case of the PP structured (twin) wall sewer pipe systems is specifically related to jetting. Jetting happens 4 times in a 100 year service life time. One jetting operation needs an energy consumption of 5 litre of gasoline and 3,75 m³ of water per 100 meter of pipe system.

4.3 End of life

The following end of life scenarios have been taken into account:

- Estimated reference service life time of 100 years based on technical assumptions
- EoL approach for landfill, incineration with energy recovery (impacts and credits are assigned to the life cycle that generates the waste flows)
- Recycled content approach for recycling and use of recyclates (= impact of recycling and credits for recyclates, because less virgin materials are needed is assigned to the life cycle that uses the recyclates)

Processes	Parameter unit expressed per functional unit
Collection process	After a reference service life time of 100 years the PP structured (twin) wall sewer pipe system might be replaced. In most cases (95%) the pipe system will be left in the ground. In some cases (5%) the pipe system is taken out and treated (mechanical recycling, incinerated or landfilled). So for the functional unit, 5,867 kg of pipe system components (pipes, fittings, manholes) are available at the trench. 2,5% (0,147 kg) is transported over an average distance of 600 km to a recycling plant, 2,5% (0,147 kg) is transported over an average distance of 150 km to an incinerator, and the remaining 95% (5,573 kg) is left in the ground. For the functional unit 0,045 kg of SBR rings are available at the trench. 5% (0,0022) will be transported to landfill over an average distance of 50 km, the rest is left in the ground.
Recycling system	
Final deposition	

		EOL scenario PP pipes and fittings, incl. PP manholes		
		Mechanical recycling	2,5%	
		Incineration	2,5%	
		Left in ground	95%	
		EOL scenario SBR rings		
		Landfill	5%	
		Left in ground	95%	
		Environmental burdens associated with transportation are calculated by means of the following Ecoinvent V3.3 datarecord "Transport, freight, lorry 3.5-7.5 metric ton, EURO4 {RER} transport, freight, lorry 3.5-7.5 metric ton, EURO4 Alloc Rec, U"		

5 ADDITIONAL INFORMATION ON EMISSIONS TO INDOOR AIR, SOIL AND WATER DURING USE STAGE

Emissions to indoor air:

Since the PP structured (twin) wall sewer pipe system is a buried system (in trench) we can confirm that emissions to indoor air are not relevant.

Emissions to soil and water:

Despite there is no approved European measurement method available, we can confirm that the PP structured (twin) wall sewer pipe system does not contain any substances mentioned on the REACH-list.

6 OTHER ADDITIONAL INFORMATION

Product certification, conformity, marking

EN 13476, Plastics piping systems for non-pressure underground drainage and sewerage - Structured-wall piping systems of unplasticized poly(vinyl chloride) (PVC-U), polypropylene (PP) and polyethylene (PE)

EN 1295-1, Structural design of buried pipelines under various conditions of loading. Part 1: General requirements

EN 1610, Construction and testing of drains and sewers

ENV 1046, Plastics piping and ducting systems - Systems outside building structures for the conveyance of water or sewage - Practices for installation above and below ground

In compliance with European Construction Products Directive (89/106/EEC)

Other technical product performances

For the full overview of the environmental benefits of plastic pipe systems we will refer to the TEPPFA website: <http://www.teppfa.eu>

List of names and logos of TEPPFA member companies



Aliaxis



Geberit International



Georg Fischer Piping Systems



Pipelife International



Polypipe



Rehau



Radius Systems



Tessenderlo Group



Uponor



Wavin

List of National Associations of TEPPFA

ADPP	- Czech Republic plastic pipes association
ASETUB	- Asociación Española de Fabricantes de Tubos y Accesorios Plásticos
BPF	- Plastic Pipes Group
BureauLeiding	- Dutch Plastic Pipes Association
DPF	- Danish Plastics Federation
FCIO	- Fachverband der Chemischen Industrie Österreich
Federplast	- De Belgische producenten van kunststof-en rubberartikels, lid bij Agoria of essencia.
FIPIF	- Finnish Plastics Industries Federation
KRV	- Kunststoffrohrverband e.V.- Fachverband der Kunststoffrohr-Industrie
MCsSz	- Műanyag Csőgyártók Szövetsége
IKEM	- Swedish Plastics and Chemical Federation
PRiK	- Polish Association of Pipes and Fittings
STR	- Syndicat des Tubes et Raccords
VKR	- Verband Kunststoffrohre und Rohrleitungstelle
Unionplast	- Federazione Gomma Plastica – Pipes Sector Group

List of names and logos of TEPPFA Associated Members



Borealis



LyondellBasell



Vynova



Lubrizol

List of names and logos of TEPPFA Supporting Members



Rollepaal



Molecor

REFERENCES

Ecoinvent, 2016. Ecoinvent database v3.3, Swiss Centre for Life Cycle Inventories, Switzerland. From: www.ecoinvent.org

EN 13476, Plastics piping systems for non-pressure underground drainage and sewerage - Structured-wall piping systems of unplasticized poly(vinyl chloride) (PVC-U), polypropylene (PP) and polyethylene (PE)

EN 1295-1, Structural design of buried pipelines under various conditions of loading. Part 1: General requirements

EN 1610, Construction and testing of drains and sewers

ENV 1046, Plastics piping and ducting systems - Systems outside building structures for the conveyance of water or sewage - Practices for installation above and below ground

Eurostat, 2006. Packaging waste scenarios (EU27, 2006). From: http://epp.eurostat.ec.europa.eu/portal/page/portal/waste/data/wastestreams/packaging_waste

ISO 14025: Environmental Labels and Declarations Type III

ISO 14040: Environmental management – Life cycle assessment – Principles and framework

ISO 14044: Environmental management – Life cycle assessment – Requirements and guidelines

EN 15804:2012+A1:2013: Sustainability of construction works – Environmental product declarations – core rules for the product category of construction products (2013)

EN 15942: Sustainability of construction works – Environmental product declarations – Communication format – Business to Business

SMP report, 2005 - Prof. Dr.-Ing. Stein & Partner GmbH – Bochum - European study of the performance of various pipe systems, respectively pipe materials for municipal sewage systems under special consideration of the ecological range of effects during the service life

Background LCA report (ISO 14040 and ISO 14044) prepared by

VITO – Flemish Institute for Technological Research, Boeretang 200, B-2400 Mol, Belgium, Tel.: +32-14-33 55 11, Email: vito@vito.be



External critical review of underlying LCA by

Denkstatt GmbH, Hietzinger Hauptstraße 28, A-1130 Wien, Austria, Tel.: +43-1 786 89 00, Email: office@denkstatt.at

