



**European Communication  
Format – B2B**

**Environmental  
Product Declaration**

**Polyvinylchloride (PVC-U)  
multilayer sewer pipe  
system with a foamed core**

## **1 DECLARATION OF GENERAL INFORMATION**

### **Introduction**

The European Plastics Pipes and Fittings Association (TEPPFA) deems it important to have an insight into the integral environmental impacts that are encountered during the life-span of particular pipe system applications. With this framework in mind, TEPPFA has set up an LCA/EPD project with the Flemish Institute for Technological Research (VITO). The present EPD outlines the various environmental aspects, which accompany the polyvinylchloride (PVC-U) multilayer sewer pipe system with a foamed core of PVC-U, from the primary extraction of raw materials up to and including the end of life (EoL) treatment after its reference service life time.

### **Name and address of manufacturers**

TEPPFA, Avenue de Cortenbergh, 71, B-1000 Brussels, Belgium, Tel: +32-2-736 24 06, Fax: +32-2-736 58 82, E-Mail: [info@teppfa.org](mailto:info@teppfa.org), <http://www.teppfa.org>

### **PVC pipe system's use and functional unit**

The EPD refers to a typical, public European sewer pipe system built of PVC-U multilayer pipes with a foamed core, from the cradle to the grave, including raw material extraction, transportation to converters, converting process, transportation to trench, construction, use and end of life. Environmental indicators are expressed for the complete life cycle, from the cradle to the grave, so for an average, typical European sewer pipe system constructed of PVC-U multilayer pipes with a foamed core. The functional unit is defined as "The below ground gravity transportation of sewage over a distance of 100 m by a typical public European PVC-U multilayer pipe system with a foamed core (Ø 250mm) from the entrance of a public sewer system to the entrance of the waste water treatment plant, over its complete service life cycle of 100 years, calculated per year".

### **Product name & graphic display of product**

PVC-U multilayer sewer pipe system with a foamed core (civil applications).

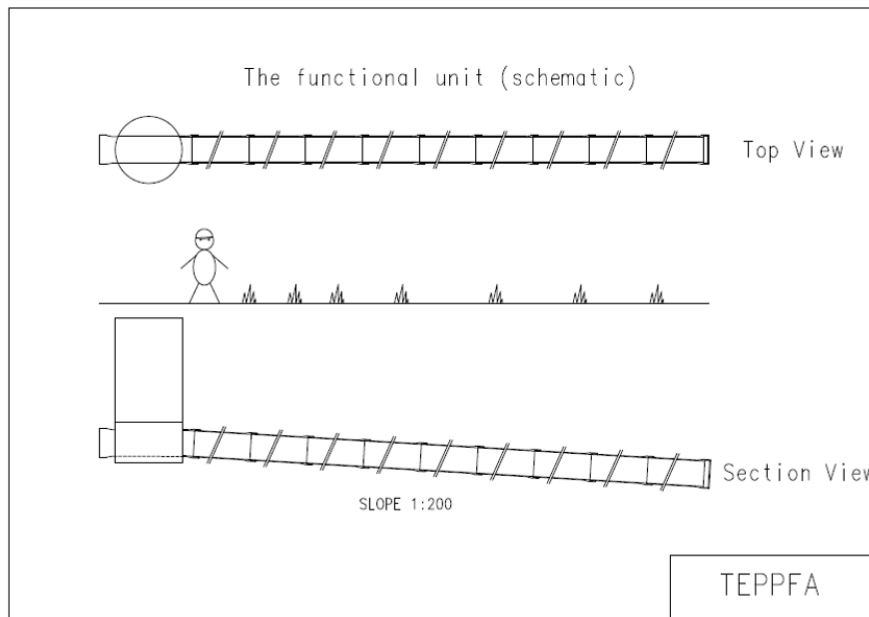

### Description of the components of the PVC-U multilayer sewer pipe system with a foamed core

The environmental burdens are calculated in relation to the functional unit, which resulted for the typical European PVC-U multilayer sewer pipe system with a foamed core in the following basic pipe system components: PVC-U multilayer pipes (with a core of foamed unplasticized PVC), PVC-U fittings, PP manholes and SBR sealing rings.

The system consists of PVC-U multilayer pipes (foamed core) and fittings, red brown, SN 4, diameter 250 mm, 5 m length, socketed (representative for the typical pipe diameters from the entrance of a public sewer system to the entrance of the waste water treatment plant).

Manhole roughly every 45 meters (630 mm shaft – SMP report, 2005). The manhole covers are not included in the LCA study. Volume of fittings including seals (approximately 5% of solid wall pipes' volume) calculated based on actual sales data. The pipe system has a reference length of 100 metres; slope 1/200 and filling rate 100%. Service life time of 100 years.

The EPD is declared as the average environmental performance for a typical European PVC-U multilayer sewer pipe system with a foamed core, over its reference service life cycle of 100 years, calculated per year, in accordance to EN 13476-1, EN 13476-2, EN 1295-1, EN 1046 and EN 1610.

### EPD programme and programme operator

The present EPD is in line with the ongoing standardization work by CEN TC 350 (prEN15804 and prEN15942). A programme operator related to the CEN TC 350 has not been established yet.

### Date of declaration and validity

Revision 1, 23 March, 2012

The EPD has a 5 year validity period (March, 2017)

### Comparability

Please note that EPDs of construction products may not be comparable if they do not comply with the CEN TC 350 (prEN15804 and prEN15942) standards.

## Typical European PVC-U multilayer sewer pipe system with a foamed core EPD

The present EPD outlines various environmental aspects, which accompany a representative average European PVC-U multilayer sewer pipe system with a foamed core of unplasticized PVC, from the primary extraction of raw materials up to and including the end of life (EoL) treatment after its reference service life time of 100 years.

### Group of manufacturers

The EPD for the PVC-U multilayer sewer pipe system with a foamed core is representative for an anticipated European typical PVC-U multilayer sewer pipe system. The TEPPFA member companies represent more than 50% of the European market for extruded plastic pipes. For an overview of all members and national associations within TEPPFA we refer to the last page of this EPD.

### Content of the product system

The product system does not contain materials or substances that can adversely affect human health and the environment in all stages of the life cycle.

### Retrieve information

Explanatory material may be obtained by contacting TEPPFA (<http://www.teppfa.org>)

## 2 DECLARATION OF THE MATERIAL CONTENT

The European Polyvinylchloride (PVC-U) multilayer sewer pipe system with a foamed core does not contain any substances as such or in concentration exceeding legal limits, which can adversely affect human health and the environment in any stages of its entire life cycle.

## 3 DECLARATION OF THE ENVIRONMENTAL PARAMETERS DERIVED FROM LCA

### 3.1 Life cycle flow diagram

The EPD refers to a typical European PVC-U multilayer sewer pipe system with a foamed core, from the cradle to the grave, including product stage, transportation to construction site and construction process stage, use stage and end of life stage.

- **Product stage:** raw material extraction and processing, recycling processes for recycled material input, transportation to the manufacturer, manufacturing (including all energy provisions, waste management processes during the product stage up to waste for final disposal):
  - Production of raw materials for PVC-U multilayer pipes with a foamed core
  - Transportation of PVC-U multilayer pipe raw materials to converter
  - Converting process for PVC-U multilayer pipes with a foamed core (extrusion), including packing of the pipes
  - Production of raw materials for PVC-U fittings
  - Transportation of PVC-U fittings raw materials to converter
  - Converting process for PVC-U fittings (injection moulding), including packing of the fittings
  - Production raw materials for PP manholes

- Converting process for PP manholes (injection moulding), including packing of the manholes
- Production raw materials for SBR rings
- Converting process for SBR rings, including packing of the SBR rings
- **Construction process stage:** including all energy provisions, waste management processes during the construction stage up to waste for final disposal
  - Transportation of PVC-U multilayer sewer pipe system with a foamed core to the trench
  - Installation of PVC-U multilayer pipe system with a foamed core in the trench
- **Use stage** (maintenance and operational use): including transportation and all energy provisions, waste management processes up to waste for final disposal during this use stage
  - Operational use is not relevant for the PVC-U multilayer sewer pipe system with a foamed core
  - Maintenance of the PVC-U multilayer sewer pipe system with a foamed core during 100 years of service life time in the trench
- **End of life stage:** including all energy provisions during the end of life stage
  - Disassembly of PVC-U multilayer sewer pipe system with a foamed core after 100 years of reference service life time at the trench
  - Transportation of PVC-U multilayer sewer pipe system with a foam core after 100 years of reference service life time at the trench to an end-of-life treatment
  - End-of-life treatment of PVC-U multilayer pipe system with a foamed core after 100 years of reference service life time

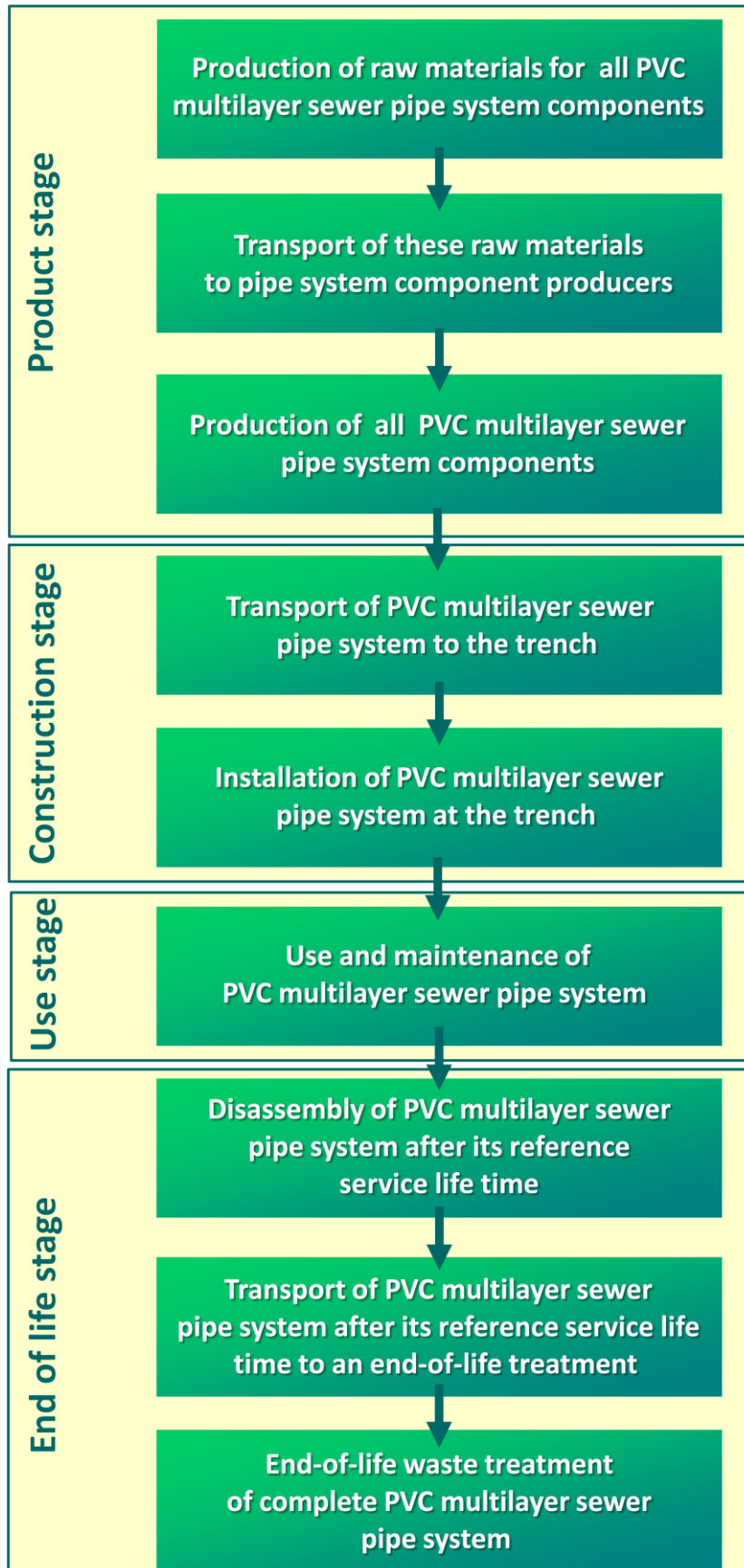

### 3.2 Parameters describing environmental impacts

The following environmental parameters are expressed with the impact category parameters of the life cycle impact assessment (LCIA).

Impact category	Abiotic depletion	Acidification	Eutrophication	Global warming	Ozone layer depletion	Photochemical oxidation
	kg Sb eq	kg SO <sub>2</sub> eq	kg PO <sub>4</sub> — eq	kg CO <sub>2</sub> eq	kg CFC-11 eq	kg C <sub>2</sub> H <sub>4</sub> eq
Product stage	0,17168	0,04639	0,01348	14,77364	0,00000024	0,00264
Construction process stage	0,04907	0,04557	0,01166	7,08671	0,00000092	0,00139
Use stage	0,00380	0,00408	0,00098	0,55092	0,00000068	0,00011
End of life stage	0,00008	0,00013	-0,00011	0,23735	0,00000011	0,000004
<b>Total</b>	<b>0,22464</b>	<b>0,09618</b>	<b>0,02602</b>	<b>22,64862</b>	<b>0,0000012</b>	<b>0,00414</b>

### 3.3 Parameters describing resource input

The following environmental parameters apply data based on the life cycle inventory (LCI).

Environmental parameter	Non-renewable energy indicator	Renewable energy indicator	Non-renewable material resources (other than energy)	Renewable material resources (other than energy)	Crude oil (feedstock and energy)	Natural gas (feedstock and energy)	Input of net fresh water
	MJ primary	MJ primary	kg	kg	kg	kg	m <sup>3</sup>
Product stage	442,06481	17,67989	0,07483	0,46570	3,69339	3,10007	21,64752
Construction stage	120,62769	3,24466	0,25195	0,01846	1,95877	0,19672	18,54930
Use stage	8,60018	0,05974	0,01668	0,00065	0,15806	0,01387	0,39644
End of life stage	-0,00327	-0,10026	0,00192	-0,00180	0,02355	-0,00353	-0,31937
<b>Total</b>	<b>571,28941</b>	<b>20,88403</b>	<b>0,34538</b>	<b>0,48300</b>	<b>5,83377</b>	<b>3,30713</b>	<b>40,27389</b>

### 3.4 Parameters describing different waste categories and further output material flows

The parameters describing waste categories and other material flows are output flows derived from the life cycle inventory (LCI).

#### Parameters describing different waste categories

Environmental parameter	Hazardous waste	Non-hazardous waste	Nuclear waste
	kg	kg	kg
Product stage	0,06461	0,39921	0,00030
Construction stage	0,00010	0,92272	0,00019
Use stage	0,00001	0,01365	0,000003
End of life stage	-0,000001	6,39635	-0,000007
<b>Total</b>	<b>0,06472</b>	<b>7,73193</b>	<b>0,00048</b>

### Parameters describing further output material flows

Parameter	Parameter unit expressed per functional unit
Components for re-use	6,152 kg
Materials for recycling	0,167 kg
Materials for energy recovery	0,177 kg

## 4 SCENARIOS AND TECHNICAL INFORMATION

### 4.1 Construction process stage

#### Transport from the production gate to the construction site (trench)

Parameter	Parameter unit expressed per functional unit
Fuel type consumption of vehicle or vehicle type used for transport e.g. long distance truck, boat etc.	The PVC-U multilayer sewer pipe system is transported over an average distance of 460 km by means of a truck from the producers of the different pipe system components to the trench. The average loading capacity is 17% with an average actual load of 5 tons. The loading factor for PVC-U multilayer pipes is limited by volume. Environmental burdens associated with this kind of transport are calculated by means of the Ecoinvent V2.2 data record "Transport, lorry 16-32t, EURO4/tkm/RER".
Capacity utilisation (including empty returns)	
Bulk density	
Volume capacity utilisation factor (factor: =1 or <1 or ≥1 for compressed or nested packaged products)	

#### Construction (installation at trench)

Parameter	Parameter unit expressed per functional unit
Ancillary materials for installation	<b>0,3 m<sup>3</sup> of backfilling sand</b> trucked to trench over an average distance of 10 km. Environmental burdens associated with this kind of energy are calculated by means of the Ecoinvent V2.2 data record "Sand, at mine/CH + Transport, lorry >32t, EURO4/tkm/RER"
Other resource consumption	Not relevant
Quantitative description of energy type (regional mix) and consumption during the installation process	<b>46 MJ of mechanical energy</b> is needed for excavating the soil (dig up), for excavating the backfilling soil and sand, for the stamping process (compaction next pipe) and for the vibration plate (compaction top). Environmental

	<p>burdens associated with this kind of energy are calculated by means of the Ecoinvent V2.2 datarecord "Diesel, burned in building machine/MJ/GLO"</p>																								
<p>Waste on the building site, generated by the product's installation</p>	<p><b>0,1 kg of PVC-U multilayer pipe left left over</b> during installation: 80% to landfill, 15% to incineration and 5% to mechanical recycling. Transportation of PVC-U pipe left over to waste management treatment facilities is included: 600 km to recycling plant, 150 km to incineration with energy recovery and 50 km to landfill. Environmental burdens are calculated by means of the Ecoinvent v2.2 datarecord "Transport, lorry 3.5-7.5t, EURO4/tkm/RER".</p> <p><b>0,2 kg of packaging waste:</b> treated according to European average packaging waste scenarios (EU27, 2006):</p> <table border="1"> <thead> <tr> <th></th> <th>Recycling</th> <th>Energy Recovery</th> <th>Landfill</th> </tr> </thead> <tbody> <tr> <td>Plastic</td> <td>27%</td> <td>26%</td> <td>47%</td> </tr> <tr> <td>Paper and board</td> <td>75%</td> <td>10%</td> <td>15%</td> </tr> <tr> <td>Wood</td> <td>38%</td> <td>23%</td> <td>39%</td> </tr> <tr> <td>Metals</td> <td>66%</td> <td></td> <td>34%</td> </tr> <tr> <td><b>Total</b></td> <td><b>57%</b></td> <td><b>12%</b></td> <td><b>31%</b></td> </tr> </tbody> </table> <p><b>0,36 m<sup>3</sup> of soil</b> that has to be transported over an average distance of 5 km to the nearest depot. Environmental burdens are calculated by means of the Ecoinvent v2.2 datarecord "Transport, lorry 3.5-7.5t, EURO4/tkm/RER".</p>		Recycling	Energy Recovery	Landfill	Plastic	27%	26%	47%	Paper and board	75%	10%	15%	Wood	38%	23%	39%	Metals	66%		34%	<b>Total</b>	<b>57%</b>	<b>12%</b>	<b>31%</b>
		Recycling	Energy Recovery	Landfill																					
Plastic	27%	26%	47%																						
Paper and board	75%	10%	15%																						
Wood	38%	23%	39%																						
Metals	66%		34%																						
<b>Total</b>	<b>57%</b>	<b>12%</b>	<b>31%</b>																						
<p>Output materials as result of waste management processes at the building site e.g. of collection for recycling, for energy recovery, final disposal</p>																									
<p>Emissions to ambient air, soil and water</p>	<p>No direct emissions at the trench. Emissions are related to the upstream processes (mining of sand, transportation processes and mechanical energy) and downstream processes (waste management and treatment) and are included in the Ecoinvent datarecords that are used for modelling the environmental impacts.</p>																								

## 4.2 Use stage: operation and maintenance

### Operation:

Operational use is not relevant for the EPD, since it falls outside the system boundaries of the LCA project. Moreover the PVC-U multilayer sewer pipe system with a foamed core is a gravity pipe system.

### Maintenance:

Energy consumption for jetting: 5,4 kWh per FU

Water consumption for jetting: 0,12 m<sup>3</sup> per FU

Maintenance in case of the PVC-U multilayer sewer pipe systems is specifically related to jetting. Jetting happens 4 times in a 100 year service life time. One jetting operation needs an energy consumption of 4 litre of gasoline and 3 m<sup>3</sup> of water per 100 meter of pipe system.



### 4.3 End of life

The following end of life scenarios have been taken into account:

- Estimated reference service life time of 100 years
- EoL approach for landfill, incineration with energy recovery (impacts and credits are assigned to the life cycle that generates the waste flows)
- Recycled content approach for recycling and use of recyclates (= impact of recycling and credits for recyclates, because less virgin materials are needed is assigned to the life cycle that uses the recyclates)

Processes	Parameter unit expressed per functional unit								
Collection process	<p>After a reference service life time of 100 years the PVC-U multilayer sewer pipe system with a foamed core might be replaced. In most cases (95%) the pipe system will be left in the ground. In some cases (5%) the pipe system is taken out and treated (landfilled or incinerated).</p> <table border="1" style="margin-left: auto; margin-right: auto;"> <thead> <tr> <th colspan="2">EOL scenario PVC pipes</th> </tr> </thead> <tbody> <tr> <td>Mechanical recycling</td> <td>2,5%</td> </tr> <tr> <td>Incineration</td> <td>2,5%</td> </tr> <tr> <td>Left in ground</td> <td>95%</td> </tr> </tbody> </table> <p>The transportation distance of the PVC-U pipe system from the trench to a waste treatment facility depends on the treatment option. For mechanical recycling we assumed an average transportation distance of 600 km and for incineration an average distance of 150 km. Environmental burdens associated with transportation are calculated by means of the following Ecoinvent v2.2 data record "Transport, lorry 3.5-7.5t, EURO4/tkm/RER"</p>	EOL scenario PVC pipes		Mechanical recycling	2,5%	Incineration	2,5%	Left in ground	95%
EOL scenario PVC pipes									
Mechanical recycling		2,5%							
Incineration	2,5%								
Left in ground	95%								
Recycling system									
Final deposition									

## 5 ADDITIONAL INFORMATION ON EMISSIONS TO INDOOR AIR, SOIL AND WATER DURING USE STAGE

### Emissions to indoor air:

Since the PVC-U multilayer sewer pipe system with a foamed core is a buried system (in trench) we can confirm that emissions to indoor air are not relevant.

### Emissions to soil and water:

Despite there is no approved European measurement method available, we can confirm that the PVC-U multilayer sewer pipe system with a foamed core does not contain any substances mentioned on the REACH-list.

## 6 OTHER ADDITIONAL INFORMATION

### Product certification, conformity, marking

**EN 13476-1:2007**, Plastics piping systems for non-pressure underground drainage and sewerage - Structured-wall piping systems of unplasticized poly(vinyl chloride) (PVC-U), polypropylene (PP) and polyethylene (PE) - Part 1: General requirements and performance characteristics

**EN 13476-2:2007**, Plastics piping systems for non-pressure underground drainage and sewerage - Structured-wall piping systems of unplasticized poly(vinyl chloride) (PVC-U), polypropylene (PP) and polyethylene (PE) - Part 2: Specifications for pipes and fittings with smooth internal and external surface and the system, Type A

**EN 1295-1**, Structural design of buried pipelines under various conditions of loading. Part 1: General requirements

**EN 1610**, Construction and testing of drains and sewers

**ENV 1046**, Plastics piping and ducting systems - Systems outside building structures for the conveyance of water or sewage - Practices for installation above and below ground

In compliance with European Construction Products Directive (89/106/EEC)

### Other technical product performances

For the full overview of the environmental benefits of plastic pipe systems we will refer to the TEPPFA website: <http://www.teppfa.org>

## TEPPFA member companies



**Aliaxis**



**Alphacan**



**EGEPLAST**



**Geberit International**



**Georg Fischer Piping Systems**



**KWH Pipe**



**Pipelife International**



**Rehau**



**Teraplast**



**Tessengerlo Group**



**Uponor**



**Wavin**

## TEPPFA member national associations

<b>ADPP</b>	- Czech Republic plastic pipes association
<b>ASETUB</b>	- Asociación Española de Fabricantes de Tubos y Accesorios Plásticos
<b>BPF</b>	- Plastic Pipes Group
<b>BPPMA</b>	- Bulgarian Plastic Pipes Manufacturers Association
<b>BureauLeiding</b>	- Dutch Plastic Pipes Association
<b>DPF</b>	- Danish Plastics Federation
<b>FCIO</b>	- Fachverband der Chemischen Industrie Österreich
<b>Federplast.be</b>	- Belgische Vereniging van Producenten van Kunststof- en Rubberartikelen bij Agoria en Assenscia
<b>FIPIF</b>	- Finnish Plastics Industries Federation
<b>IPPMA</b>	- Irish Plastic Pipe Manufacturers Association
<b>KRV</b>	- Kunststoffrohrverband e.V.- Fachverband der Kunststoffrohr-Industrie
<b>MCsSz</b>	- Műanyag Csőgyártók Szövetsége
<b>P&amp;K</b>	- Swedish Plastics and Chemical Federation
<b>PRIK</b>	- Polish Association of Pipes and Fittings
<b>STR</b>	- Syndicat des Tubes et Raccords
<b>VKR</b>	- Verband Kunststoffrohre und Rohrleitungstelle

## REFERENCES

Ecoinvent Data v2.2, 2010, Swiss Centre for Life Cycle Inventories, Switzerland

EN 13476-1:2007, Plastics piping systems for non-pressure underground drainage and sewerage - Structured-wall piping systems of unplasticized poly(vinyl chloride) (PVC-U), polypropylene (PP) and polyethylene (PE) - Part 1: General requirements and performance characteristics

EN 13476-2:2007, Plastics piping systems for non-pressure underground drainage and sewerage - Structured-wall piping systems of unplasticized poly(vinyl chloride) (PVC-U), polypropylene (PP) and polyethylene (PE) - Part 2: Specifications for pipes and fittings with smooth internal and external surface and the system, Type A

EN 1295-1, Structural design of buried pipelines under various conditions of loading. Part 1: General requirements

EN 1610, Construction and testing of drains and sewers

ENV 1046, Plastics piping and ducting systems - Systems outside building structures for the conveyance of water or sewage - Practices for installation above and below ground

Eurostat, 2006, Packaging waste scenarios (EU27, 2006)

ISO 14025: Environmental Labels and Declarations Type III

ISO 14040: Environmental management – Life cycle assessment – Principles and framework

ISO 14044: Environmental management – Life cycle assessment – Requirements and guidelines

prEN 15804: Sustainability of construction works – Environmental product declarations – core rules for the product category of construction products (draft, 2008)

prEN 15942: Sustainability of construction works – Environmental product declarations – Communication format – Business to Business (draft, April 2009)

Simapro 7.3.0 – LCA Software, 2011, PRé consultants bv, Amersfoort, The Netherlands

SMP report, 2005 - Prof. Dr.-Ing. Stein & Partner GmbH – Bochum - European study of the performance of various pipe systems, respectively pipe materials for municipal sewage systems under special consideration of the ecological range of effects during the service life

### **Background LCA report (ISO 14040 and ISO 14044) prepared by**

VITO – Flemish Institute for Technological Research, Boeretang 200, B-2400 Mol, Belgium, Tel.: +32-14-33 55 11, Email: [vito@vito.be](mailto:vito@vito.be)



### **External critical review of underlying LCA by**

Denkstatt GmbH, Hietzinger Hauptstraße, AU-1130 Wien, Austria, Tel.: +43-1 786 89 00, Email: [office@denkstatt.at](mailto:office@denkstatt.at)

